

APPROVED BY

SIGN

PRINT



JEFCO MFG INC
FT. LAUDERDALE
 PH 954-527-4220
 WWW.JEFCOMFG.COM

MATERIAL:

Stainless Steel

REVISIONS:

MATERIAL ALLOY:

T-304

TOLERANCES:

STANDARD DIE CUT EDGES.
 ALL DIMENSIONS TO BE HELD TO
 +/- .015"
 NOTE ALL PRODUCTS ARE QUOTED
 USING STANDARD MILL GAGE
 MATERIAL. DO NOT SCALE

FINISH:

Mill

DESC:

S.S 11 GA. Cane Bolt Guide

COMPANY:

DATE:

11/19/08

DWG BY:

SPK

NO:

11518

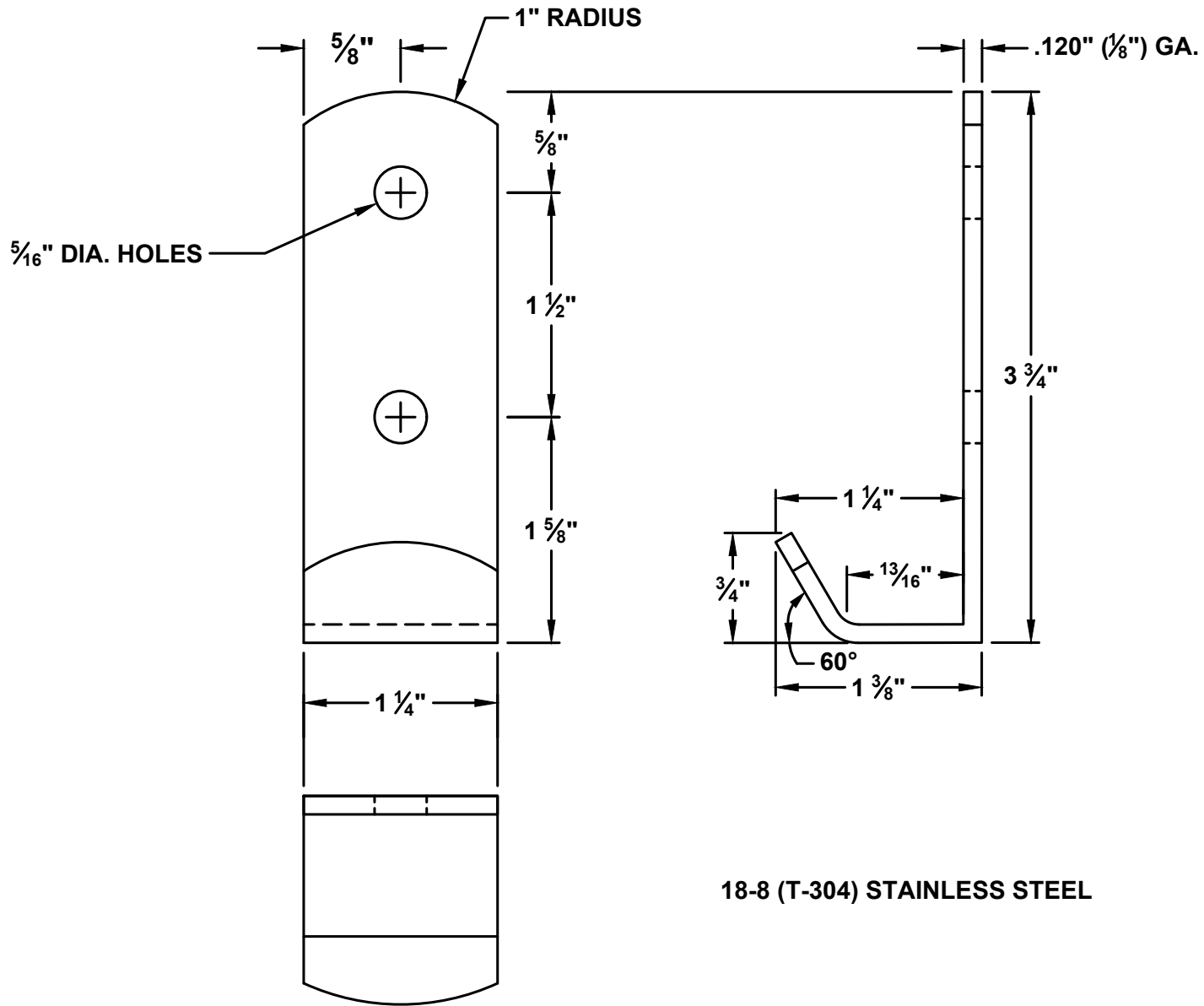

18-8 (T-304) STAINLESS STEEL

| | | | | | | |
|-------------|--|------------------------|--|--|-----------------|--------------|
| APPROVED BY |  JEFCO MFG INC FT. LAUDERDALE PH 954-527-4220 WWW.JEFCOMFG.COM | MATERIAL: | MATERIAL ALLOY: | FINISH: | DATE: | DWG BY: |
| SIGN | | Stainless Steel | T-304 | Mill | 11/19/08 | SPK |
| PRINT | | REVISIONS: | TOLERANCES: | DESC: S.S 11 GA. Cane Bolt Hook | | |
| | | | <small>STANDARD DIE CUT EDGES. ALL DIMENSIONS TO BE HELD TO +/- .015". NOTE ALL PRODUCTS ARE QUOTED USING STANDARD MILL GAGE MATERIAL. DO NOT SCALE</small> | COMPANY: | NO: | 11519 |